



# RoboLabs

Incredible machines for fastfood & funfood

## OPERATING MANUAL SUGARLIPS 10 (CP-10)



**CAUTION: READ THE INSTRUCTIONS  
BEFORE USING THE MACHINE!**

*PDF version of this manual is available on [www.robolabs.pro](http://www.robolabs.pro)*

# Table of contents

Safety requirements.....	3
1. Overview.....	4
1.1. Purpose.....	4
1.2. Technical specifications .....	4
1.3. Delivery set .....	4
1.4. Power requirements .....	4
1.5. Safety components.....	5
1.6. Ambient conditions .....	5
1.7. Main components .....	6
1.8. Getting started.....	6
2. Intended use.....	7
2.1. Caramel recipes .....	7
2.2. Machine operation.....	7
2.3. Product quality .....	9
3. Maintenance .....	10
4. Troubleshooting .....	11
5. Transportation and storage.....	11
6. Acceptance certificate.....	12
7. Warranty obligations .....	13
8. Manufacturer details .....	13
Annex A. Electric components list.....	14
Annex B1. Temperature regulator settings.....	15
Annex B2. Timer settings.....	15
Annex C. Replacing sealing rings .....	16

# Safety requirements



DO NOT DISASSEMBLE CARAMELIZER OR REMOVE SEPARATE COMPONENTS WHILE EQUIPMENT IS CONNECTED TO THE MAINS!



READ CAREFULLY THE MANUAL BEFORE START!  
ONLY INSTRUCTED PERSONNEL ARE ALLOWED TO OPERATE THE MACHINE!



IT IS PROHIBITED TO RUN THE MACHINE WITH EMPTY KETTLE! IT WILL LEAD TO MACHINE OVERHEATING AND FAILURE!



DO NOT USE THE MACHINE FOR MIXING HEAVY OR ABRASIVE PRODUCTS!



MANY PARTS ARE HOT WHILE IN OPERATION!  
BURN HAZARD!



BEWARE OF MOVING PARTS OF THE MACHINE WHILE IN OPERATION!

	<b>WARNING</b> RISK OF FIRE OR ELECTRIC SHOCK DO NOT OPEN	
WARNING, TO REDUCE THE RISK OF FIRE OR ELECTRIC SHOCK, DO NOT REMOVE COVER (OR BACK) NO USER-SERVICEABLE PARTS INSIDE REPAIR SHOULD BE DONE BY AUTHORIZED SERVICE PERSONNEL ONLY		

# 1. Overview

## 1.1. Purpose

SugarLips CP-10 machine intended for cooking caramel and coating popped popcorn with it (hereinafter – “caramelizer” or “machine”).

## 1.2. Technical specifications

Productivity	up to 14 kg/hr (30 lbs/hr)
Kettle size	38 liters (10 gallons)
Ampacity	12 A
Rated voltage	3/N/PE AC 230/400 V 50/60 Hz
Rated power	5.5 kW
Dimensions (LxWxH)	760x500x900 mm
Weight	50 kg
Ingress protection	IP22

## 1.3. Delivery set

Caramelizer	1 pc
Popcorn container 38 liters (10 gallons)	1 pc
Kettle lid	1 pc
Spare parts set (PTFE mixer pad, PTFE and rubber sealing rings)	1 set
Documentation	1 set

## 1.4. Power requirements



ELECTRIC SOCKET MUST HAVE GROUNDING CONTACT!



CONNECTIONS MUST BE DONE ONLY BY QUALIFIED ELECTRICIAN!



IF SUPPLY CORD DAMAGED, IT MUST BE REPLACED BY MANUFACTURER, SERVICE AGENT, OR QUALIFIED PERSONS IN ORDER TO AVOID HAZARD!

It is necessary to periodically check electric connections, including grounding connection. Whenever any fault conditions are found, do not turn the equipment on, and call for qualified electrician!

Equipotential bonding wire (up to 10 sq.mm) shall be connected to screw

terminal marked with IEC 5021 sign. 

Cable plug is not included in the delivery set. Use a 16 A plug. Refer to the wiring diagram on the power cord label.

It is necessary to check electric wires and ground connection of the machine periodically. In case of faults found, an electrician must be called. It is allowed to turn the machine on only after all the issues are resolved.

## 1.5. Safety components

The machine can be turned off in any time with the main switch on the front panel.

There is an emergency temperature regulator located in heating elements area. In case of excessive or uncontrolled heating it will cut off power supply to the heaters.

## 1.6. Ambient conditions

The equipment must be operated at the ambient temperature from +5° to +40°C and relative humidity not more than 45% at 40°C. The temperature decreasing related to RH increasing, for example, 90% of RH at 20°C. Altitude above sea level should not exceed 1000 m. Ingress protection rating IP22 (IEC 60529).

During the operation, machine emits a lot of steam and heat. It is essential to provide exhausting hood (800x800 mm, 500 cu.m/hr or more) installed over the kettle.

Ambient conditions have strong impact on the end product quality. See section 2.3 for more details.

## 1.7. Main components

Caramelizer has following components: 1 – Kettle with mixer and heaters; 2 – Control unit; 3 – Mount base, see Fig.1:



Fig. 1 Main components

## 1.8. Getting started

Unpack machine carefully, check delivery set, and remove protective film from all surfaces. Put the machine on special table (not included in the delivery set). Connect to electric service.

## 2. Intended use

### 2.1. Caramel recipes

Below are few caramel recipes to start with. Depending on customer's needs, those recipes may be modified or substituted with your own recipes. Feel free to experiment with different recipes to get the best results.

#### *Caramel recipe no. 1:*

Super Caramel Premix or similar – 1300 g

Sugar (beet or cane) – 1200 g

Coconut oil or butter – 200 g

Water – 500 g

Lecithin Free-N-Easy<sup>1</sup>

#### *Caramel recipe no. 2:*

Super Caramel Premix or similar – 1050 g

Sugar (beet or cane) – 750 g

Coconut oil or butter – 150 g

Water – 375 g

#### *Caramel recipe no. 3:*

Super Caramel Premix or similar – 1100 g

Sugar (beet or cane) – 1000 g

Coconut oil or butter – 200 g

Water – 300 g

### 2.2. Machine operation

Machine controls has following items on control panel:

---

<sup>1</sup> Free'N'Easy lecithin helps popcorn not to stick to each other. Lecithin should be applied onto popcorn in the middle of mixing stage.

- Temperature regulator
- Main switch 3-pos.

The main switch has three positions: HEATING, OFF, MIXING.

## *Heating stage*

The switch is in HEATING position. The mixture in the kettle is being heated and periodically stirred with the mixer, to provide proper mixing of all ingredients. Once temperature set point is reached, operator will hear the sound alarm.

## *Mixing stage*

The switch is in MIXING position. Heaters are not energized, mixer operates continuously.

## *Operation order*

To make caramel coated popcorn, do the following:

1. Apply liquid lecithin on the kettle sidewall, to minimize caramel stuck.
2. Put caramel ingredients into the kettle. Put popped popcorn into popcorn container.
3. Turn the main switch to HEATING position; adjust the temperature set point if necessary.
4. Wait for sound signal.
5. Once temperature is reached, set the switch in MIXING position and dump prepared popcorn in the kettle.
6. Apply liquid lecithin during mixing, to help popcorn being separated.
7. Once popcorn is properly coated with caramel, tip the kettle with handle, discharging popcorn onto cooling table<sup>2</sup>.
8. Once kettle is empty, get the kettle back to straight position and set the switch to OFF position.

---

<sup>2</sup> Cooling table is not included in the delivery set and must be purchased separately.



## 2.3. Product quality

### *Temperature adjustment*

Due to constructive features, temperature value set on the thermoregulator may be different, depending on recipes used. The goal is to get good taste rather than reach some temperature value.

The following recommendations will help you to find out the right temperature that should be set on the thermoregulator.

Make a batch of caramelized popcorn with default temperature setting (165°C) and give it a try.

If caramel is sticky to the tooth, it means that caramel is *undercooked*; therefore, the temperature value must be *increased*.

If caramel has bitter taste with hint of burnt, it means that caramel is *overcooked*; therefore, the temperature value must be *reduced*.

Caramel that cooked with normal temperature and properly cooled is crunchy and doesn't stick to the tooth.

### *Popcorn crunchiness*

Crunchiness of caramel coated popcorn comes mostly from caramel layer. To be crispy, caramel should be properly cooked, which means that there is virtually no water left in the mix.

However, even if caramel is cooked properly, the result may be not so good. Popcorn is highly hygroscopic product. It is very important to make sure that popcorn you put into the machine has not more than 1.0—1.5% of moisture. Otherwise, excessive moisture will ingress into caramel layer after coating and make it sticky.

Except providing proper ambient conditions (see section 1.5), some additional equipment may be required in order to keep popcorn in good condition at intermittent stages as well as finished product.

### 3. Maintenance

The maintenance purpose is to keep the machine operable during the entire service life. The recommended<sup>3</sup> maintenance schedule with types of actions is presented below:

PROCEDURE	PERIOD
Kettle cleaning	once a day
Outer surface cleaning	once a day



DISCONNECT THE MACHINE FROM THE MAINS BEFORE TECHNICAL MAINTENANCE!



DO NOT USE SHARP TOOLS OR ABRASIVES!



DO NOT LET ALL WATER TO BOIL OUT!



DO NOT PUT MORE THAN 2 LITERS OF WATER INTO THE KETTLE!



DO NOT REMOVE THE LID WHILE KETTLE IS HOT!  
HOT STEAM INSIDE! BURN HAZARD!

#### *Kettle Cleaning*<sup>4</sup>

Pour *not more than 2* liters of water in the kettle, close the kettle with lid provided in the delivery set, and turn the main switch in ON position. Wait until water is started to boil; let it boil for a few minutes, so hot water steam will be able to fill the kettle properly. Turn off the machine and let the kettle to cool down.

In case of severe carbon build ups, use special cleaning product (Heet-N-Kleen or similar).



DURING MACHINE OPERATION SOME AMOUNT OF DARK-COLOURED CONDENSATE MAY BE FOUND BELOW THE KETTLE, ON MIXER MOTOR HOUSING AND AROUND. IT SHOULD BE REMOVED AS NECESSARY!

<sup>3</sup> Period may be different. Maintenance procedures must be done as necessary.

<sup>4</sup> The machine must be turned on for kettle cleaning procedure.

## 4. Troubleshooting

Problem	Possible cause	Possible remedy
Caramel coated popcorn is not crunchy	Popcorn is still too hot Too low temperature set value Improper recipe Popcorn had excessive moisture before coating. Extreme ambient conditions.	Make sure that popcorn is properly cooled down Increase the temperature set value Use proper recipe Make sure that moisture content of popped popcorn being put in the machine does not exceed 1.5% Provide proper ambient conditions and purge ventilation.
Caramel coated popcorn is too dark and/or has bitter taste.	Too high temperature set value Improper recipe	Decrease the temperature set value Use proper recipe
Dark thick liquid appears under the kettle (next to the motor and the shaft)	Irregular outer surface cleaning Mixer sealing rings are worn out. Mixer sealing rings are not in proper order.	Perform cleaning as necessary, on regular basis Replace the sealing rings, see Annex C. Make sure that sealing rings are put in proper order, see Annex C.

## 5. Transportation and storage

The equipment may be transported by any kind of covered vehicle, in accordance with transportation rules for this kind of vehicle.

Ambient temperature during the transportation and storage must be between minus 25°C and +55°C.

## 6. Acceptance certificate

ACCEPTANCE CERTIFICATE	
_____ Product Name	_____ Serial No.
The equipment is made with accordance to mandatory requirements of the state standards, actual technical documentation, and approved for use.	
QC Engineer	
STAMP HERE	
_____ Signature	_____ Full Name
_____ DD.MM.YYYY	

## 7. Warranty obligations

The manufacturer guarantees trouble-free operation of the equipment during 12 months from the date of receiving the equipment by dealer (in accordance with transport documentation); or, in case of purchase directly through Trapeza LLC, from the purchase date, given that terms of using, transportation, and storage are met.

The warranty repair is performed upon presentation of this manual and filled warranty card with the seller's seal and the date of sale.

Technical specifications of the equipment can be changed by manufacturer at any time due to improvements and/or other reasons. Technical specifications stated in this document are intended to act as a reference point, which is necessary to evaluate suitability of the equipment for the customer's needs, and are not the subject of warranty policy.

The information stated in this document has been thoroughly checked and considered as accurate one; nevertheless, the manufacturer is not responsible for any typographical errors or misprints.

**Due to constant improvement of the equipment, technical specifications are subject to change without prior notice!**

## 8. Manufacturer details

NPO Tvertorgmash LLC

11 Industrial Street, Tver, 170000 Russia

Technical support:

Email: [support@robolabs.pro](mailto:support@robolabs.pro)

Phone: +7 495 956 4000

## Annex A. Electric components list

SIGN	DESIGNATION	MODEL	SPECS
AT	Safety thermostate	TK24-13-1-220 Thermorex	230 Vac, 16 A
BT	Temperature sensor	ДТПК124-00.32/4 Owen	Type K
C1	Capacitor	ДПС-0,45-30 Electointer	450 Vac, 8 uF
DC1	Temperature regulator	TC4SP, Autonics	230 Vac
	DC1 socket	PS-11, Autonics	—
DC2	Timer	AT8N, Autonics	230 Vac
	DC2 socket	PS-08, Autonics	—
EK1, EK2, EK3	Heater	1GIK3CG41002, IRCA	230 Vac, 30Ω
FU	Fuse 8,5x31,5	DF2BA1000 Schneider Electric or E9F8GG10, ABB	400 Vac, 10A
	Fuse holder	DF83 Schneider Electric or E93/20, ABB	690 Vac, 20A
HA	Buzzer	SC235B, Sonitron	24 Vdc
KM	Contactora	LC1D09M7, Schneider Electric	230 Vac, 9A
M1	AC motor with gearbox	Y100-140F 104JB30G1542, Linix	400/230 Vac
QF	Circuit breaker	S203-C16, ABB	400 Vac 16 A
SA	Switch	B101S30, Emas	4A
TV	Power supply	DVPPS02, Delta	24Vdc, 2A
VS1, VS2, VS3	Solid state relay	SA842070, Celduc	25A, 4-32 Vdc
VS4	Solid state relay	SAL963460, Celduc	35A, 4-32 Vdc

# Annex B1. Temperature regulator settings



PARAMETER	VALUE	DESCRIPTION
In-t	KCAH	Temperature sensor thermocouple K type
L-Su	90	Low limit set point value
H-Su	180	High limit set point value
out	SSr	Control output: to solid-state relays
AL-1	AL1 <input type="checkbox"/> AL2 <input type="checkbox"/>	Alarm operation mode
ALYS	5	Alarm output hysteresis
AL1	-2	Alarm temperature setting
P	120	Proportional band
I	400	Integral time setting (integral component)
D	150	Derivative time setting (derivative component)
LoC	LoC2	Lock settings (all settings, except Operating temperature)

Default temperature set value (SV) is 165°C.

# Annex B2. Timer settings



Mode – F1, default set value – 12 seconds.

## Annex C. Replacing sealing rings

In the upper part of the mixer there are two sealing rings, which are subject to wear and tear.

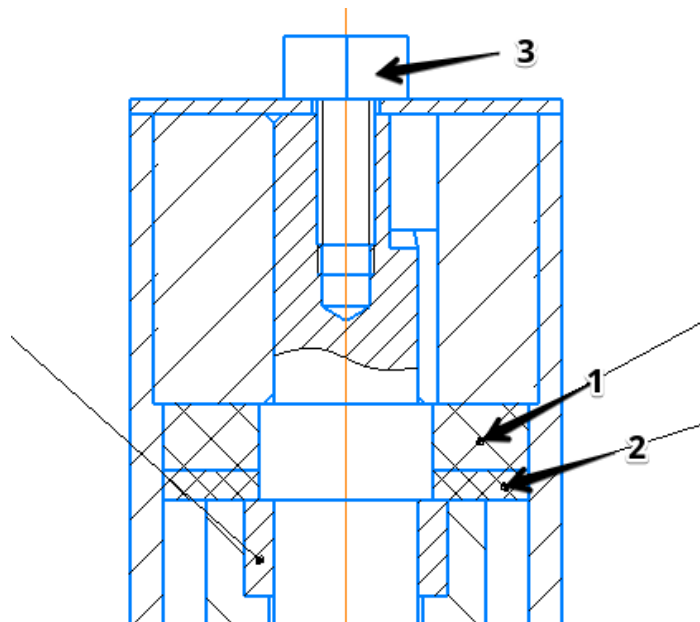

Fig. 2 Mixer sealing rings: 1 – PTFE ring; 2 – Rubber sealing ring; 3 – Fixing screw bolt

To replace the rings, loose the fixing bolt, take off the mixer from the shaft, replace old rings with new ones, note the correct disposition order – rubber sealing ring must be under PTFE ring.